

Installation Instructions

Original Instructions



Allen-Bradley
by ROCKWELL AUTOMATION



SensaGuard 18 mm Cylindrical Barrels (Series B Models Only)

Catalog Numbers

Low-level Coding: 440N-Z21S16A, 440N-Z21S16B, 440N-Z21S16H, 440N-Z21S16J, 440N-Z21S17A, 440N-Z21S17B, 440N-Z21S17H, 440N-Z21S26A, 440N-Z21S26B, 440N-Z21S26H, 440N-Z21S26J, 440N-Z21S17J, 440N-Z21X16H, 440N-Z21S16E, 440N-Z21S17B-PUR

High-level Coding: 440N-Z21U16A, 440N-Z21U16B, 440N-Z21U16H, 440N-Z21U16J, 440N-Z21U17A, 440N-Z21U17B, 440N-Z21U17H, 440N-Z21U26A, 440N-Z21U26B, 440N-Z21U26H, 440N-Z21U26J, 440N-Z21U17J

IMPORTANT Save these instructions for future use.	
Topic	Page
Specifications	2
Approximate Dimensions	2
Mode of Operation	2
Installation	3
Diagnostics	3
Typical Wiring	3
Commission the Unique Coded Actuator	4
Unique Coded Diagnostic	4
OSSD Test Pulses	5
Timing Diagram	5
Troubleshooting	6
Application Wiring Examples	6
Recommended Safety Control Interfaces	11
Maintenance	11
Repair	11
Additional Resources	12

Summary of Changes

This publication contains the following new or updated information. This list includes substantive updates only and is not intended to reflect all changes.

Topic	Page
Updated Certifications	2
Added Recommended Safety Control Interfaces	11
Added Maintenance	11
Added Repair	11
Added Declaration of Conformity	12

Installation must be in accordance with the following instructions and specifications and implemented by suitable competent personnel. Adherence to the recommended maintenance instructions forms part of the warranty.

Do not use this unit as a mechanical stop. You must fit guard stops and guides.

This device is intended to be part of the safety-related control system of a machine. Before installation, you must perform a risk assessment to determine whether the specifications of this device are suitable for all foreseeable operational and environmental characteristics.



WARNING: Do not defeat, tamper, remove, or bypass this unit. Severe injury to personnel can result.



ATTENTION: You must provide this device with a 24V DC PELV or SELV power supply that conforms to the requirements of 414-3 of IEC 60364-4-41 where provisions are taken. The voltage at the outgoing terminals cannot exceed 60V DC, even if there is an internal fault. Improper selection or installation of the devices affects the integrity of the safety systems.

Personal injury or death, property damage, or economic loss can result.

Comply with ISO 14119 including section, accessibility to the installation, arrangement, and mounting, possible substitute actuation, access to the escape release, motivation to defeat, and actuation mode.

Use management controls, working procedures, training, and additional protective measures to minimize the motivation to defeat and to manage the use and availability of spare actuators.

Comply with ISO 13857 and ISO 13855 for guard openings and minimum (safe) distances.

Comply with ISO 13849-1 and ISO 13849-2 for functional safety.

This product is intended for industrial/business application only. This product is not intended for use in residential applications, as it can cause radio interference on other residential devices.



ATTENTION: Read this document and the documents that are listed in [Additional Resources on page 12](#) before you install.

Familiarize yourself with the installation and connection instructions and requirements of all applicable codes, laws, and standards.

In accordance with applicable codes of practice, suitably trained personnel must implement installation, adjustments, service initiation, use, assembly, disassembly, and maintenance.

Use of this equipment that is not specified by the manufacturer can impair the protection that the equipment provides.



ATTENTION: Do not attempt to install this device unless you study and understand the installation instructions. This document acts as a guide for a typical installation.

Specifications

Attribute	18 mm Plastic Actuator	30 mm Plastic Actuator	18 mm Stainless-steel Actuator
Safety Ratings			
Standards safety classification	IEC 60947-5-3, Cat. 4 PL e Per ISO 13849-1, Type 4 Interlocking Device according to ISO 14119 with either low (standard) or high (unique) coding, SIL CL 3 per IEC 61508		
Functional safety data	PFH _D = 1.32E-9 (probability of dangerous failure per hr) T1 = 20 (proof test interval)		
Certifications	CE Marked for all applicable EU directives, UKCA Marked for all applicable regulations, cULus Listed (UL 508), and TÜV Certified rok.auto/certifications		
Operating Characteristics			
Sensing distance, assured on [mm (in.)]	15 (0.59)	25 (0.98)	10 (0.39)
Sensing distance, assured off [mm (in.)]	25 (0.98)	35 (1.78)	20 (0.79)
Operating voltage	24V DC 10%/-15% Class 2 SELV or PELV power supply		
Response time (off)	45 ms		
Utilization category	DC-12 and DC-13 Ue: 24V Ie: 200 mA		
Frequency of operating cycle	0.25 Hz		
No-load supply current	< 50 mA		
Outputs (OSSD)			
Safe state	De-energized (2 x PNP, OV), AUX energized (1 x PNP, 24V)		
Run state	Energized (2 x PNP, 24V), AUX de-energized (1 x PNP, OV)		
Load current, max	200 mA		
Voltage drop	< 1.5V		
Switches connected in series	Unlimited (see Timing Diagram on page 5)		
Mechanical			
Sensor case material	Polycarbonate		Stainless steel 304
Actuator case material	Polycarbonate		Stainless steel 304
Environmental			
Operating temperature [C° (F°)]	-25...+70 (-13...+158)		
Operating humidity	5...95% relative		
Washdown rating	IP66, IP67, IP69K		
Shock and vibration	IEC 60068-2-27: 30 g, 11 ms IEC 60068-2-6: 10...55 Hz		
Pollution degree	IEC 60947-1-3		
Electromagnetic Compatibility (EMC)			
Electrostatic discharge ESD	IEC 61000-4-2: Air discharge Per IEC 61326-1 (functional): 8 kV Per IEC 61000-6-7 (fail-safe): 8 kV IEC 61000-4-2: Contact discharge Per IEC 61326-1 (functional): 4 kV Per IEC 61000-6-7 (fail-safe): 6 kV		
Radiated EMF immunity	IEC 61000-4-3 Per IEC 61326-1 (functional): 10V/m Per IEC 61000-6-7 (fail-safe): 20V/m		
Electrical fast transient/burst immunity	IEC 61000-4-4 Per IEC 61326-1 (functional): 2 kV/5 kHz Per IEC 61000-6-7 (fail-safe): 2 kV/5 kHz		
Conducted immunity	IEC 61000-4-6 Per IEC 61326-1 (functional): 10V Per IEC 61000-6-7 (fail-safe): 20V		
Rated impulse withstand voltage	IEC 60947-1: 1 kV		
Protection	Short circuit, overload, reverse polarity, overvoltage, loss of ground		
Physical Characteristics			
Torque settings, max [N•m (lb•in)]	Switch/actuator mounting nut: 2.20 (19.5)		

Approximate Dimensions

Figure 1 - 18 mm Plastic Barrel [mm (in.)]

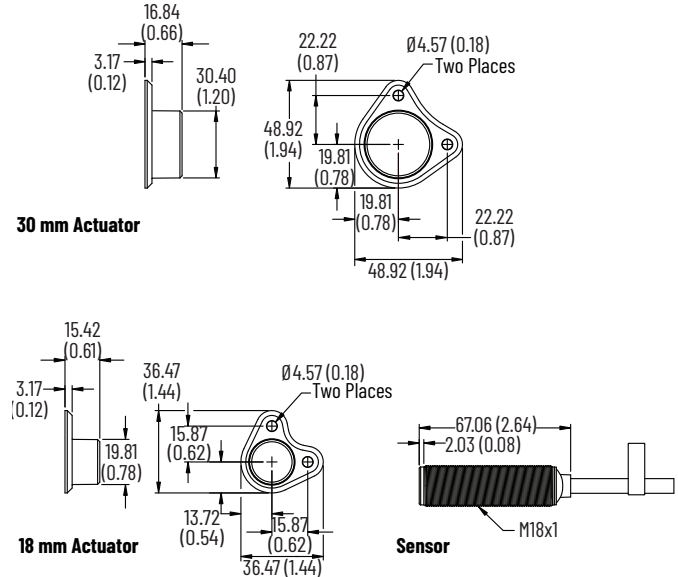
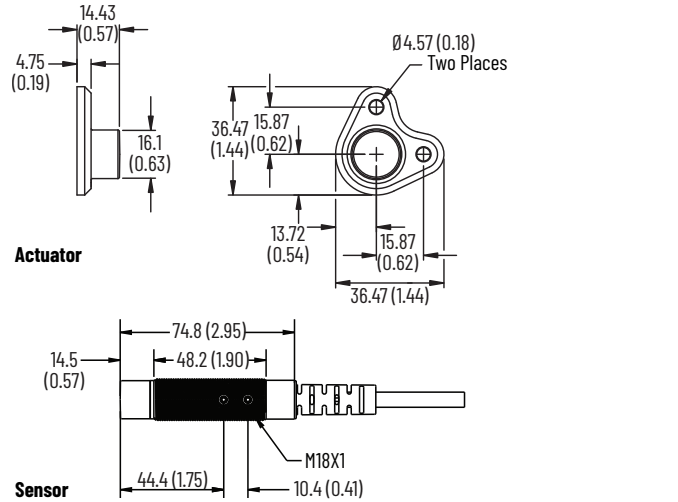
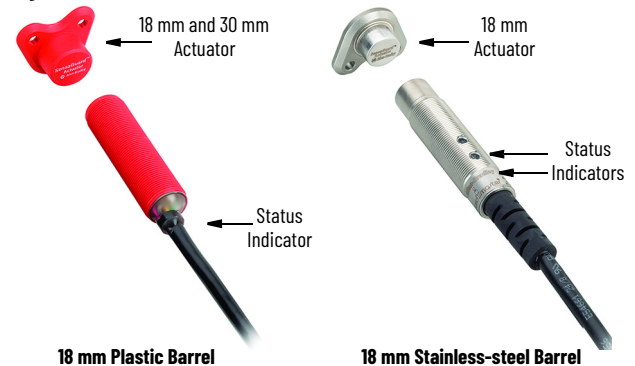

Figure 2 - 18 mm Stainless-steel Barrel [mm (in.)]



Mode of Operation

Figure 3 - Status Indicators



- Actuator is supplied with the sensor
- Status indicator green: Door/guard closed, safety outputs active.
- Status indicator red: Door/guard open, safety outputs off.
- Status indicator flashes red: Unit failure. See [Table 1 on page 3](#).
- Status indicator flashes green: Safety inputs off.

Diagnostics

Table 1 - Signal from Status/Diagnostic Indicator

State	Status	Troubleshooting
Off	Not powered	—
Red	OSSD not active	—
Green	OSSD active	—
Green flash	Power up test or OSSD inputs not valid	Check 24V DC or OSSD inputs (yellow or red wire).
Red flash	0.5 Hz flash OSSD fault	OSSD fault: Check that OSSD outputs are not shorted to GND, 24V DC or each other.
	2 Hz flash internal fault	Cycle power.

Installation

IMPORTANT Do not over torque the mounting hardware. See [Torque settings, max on page 2](#).

Use nonremovable screws, bolts, or nuts to mount the switch and actuator. Position the switch and actuator so they align with each other.

Figure 4 - Minimum Distance Between Sensors [mm (in.)]
Stainless-steel Housing

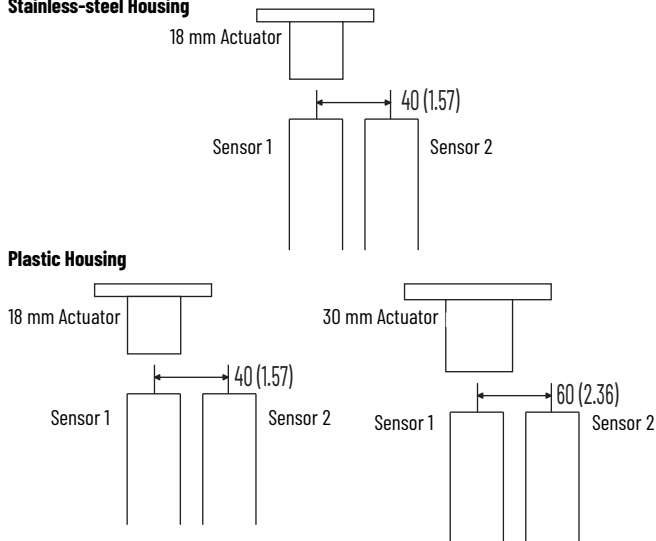
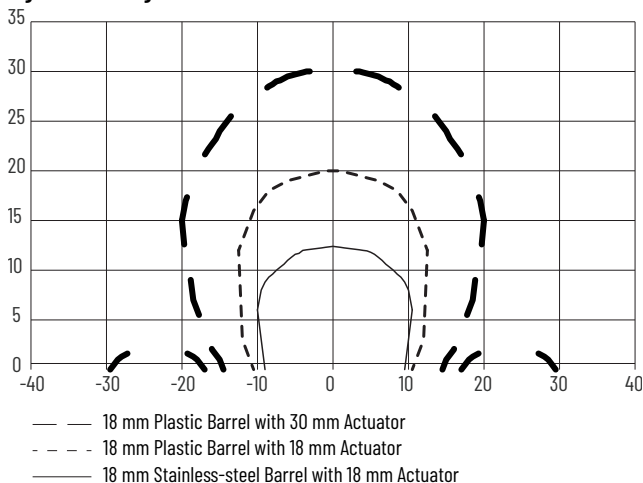
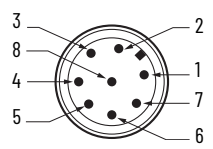

Figure 5 - Misalignment Curve



Typical Wiring

Table 2 - 8-pin Diagram



Pin	Color	Signal
1	White	Auxiliary Output
2	Brown	24V DC
3	Green	— (1)
4	Yellow	OSSD 2 Input
5	Gray	OSSD 1 Output
6	Pink	OSSD 2 Output
7	Blue	0V
8	Red	OSSD 1 Input

The recommended mating cable is 2 m (6.5 ft) (catalog number 889D-F8AB-2). Replace the 2 with 5 (5 m [16.4 ft]) or 10 (10 m [32.8 ft]) for standard cable lengths.

(1) Shield wire for the stainless-steel version.

Table 3 - 5-pin Diagram

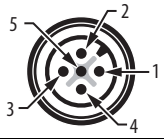

Pin	Color	Signal
1	Brown	+24V
2	White	Safety OSSD 1 Output
3	Blue	0V
4	Black	Safety OSSD 2 Output
5	Gray	Auxiliary Output

The recommended cordset is 2 m (6.5 ft) (catalog number 889D-F5AC-2). Replace the 2 with 5 (5 m [16 ft]) or 10 (10 m [32.8 ft]) for standard cable lengths.

IMPORTANT If you do not require an auxiliary signal, use a 4-pin cordset (catalog number 889D-F4AC-2).

The recommended patchcord for use with ArmorBlock® Guard Safety I/O is 2 m (6.5 ft) (catalog number 889D-F4ACDM-2). Replace the 2 with OM3 (0.3 m [0.98 ft]), 1 (1 m [3.28 ft]), 5 (5 m [16.4 ft]), or 10 (10 m [32.8 ft]) for standard cable lengths.

IMPORTANT Do not use a 5-pin patchcord with the ArmorBlock I/O.

Commission the Unique Coded Actuator

Power the Sensor

Connect the sensor to 24V DC (see [Typical Wiring on page 3](#)).

IMPORTANT The unique coded sensor ships from the factory unprogrammed and must be taught a unique coded actuator, see [Teach the Actuator](#).
 A unique coded sensor can only learn a unique coded actuator and cannot learn a standard coded actuator. A standard coded sensor does not work with a unique coded actuator.
 The unique coded sensor Status/Diagnostic indicator, flashes green eight times then repeats, which indicates that the sensor has not yet learned an actuator. You can lock the unique coded sensor so it cannot learn another actuator, see [Teach the Unique Actuator](#).

Teach the Actuator

(ability to learn an additional actuator)

Quick Start

1. Power up the sensor and bring an actuator into the sensing range.
2. Leave the actuator in the sensing field for a minimum of 2 minutes.
3. The learn process is complete.

IMPORTANT The sensor can learn a new actuator up to eight times. The Status/Diagnostic indicator flashes the number of actuators left that a sensor can learn.

Ability to Learn an Additional Actuator

The sensor automatically starts the learn process once an actuator enters the sensing range.

Table 4 - Learn Sequence

Step	Description
1	Target present Status/Diagnostic indicator flashes green 2 Hz rate (15 s)
2	Verifying actuator Status/Diagnostic indicator flashes green/red 1 Hz rate (15 s)
3	Program sensor Status/Diagnostic indicator flashes green/red 2 Hz rate (15 s)
4	Program complete Status/Diagnostic indicator flashes green 2 Hz rate (number of learns that remain) (15 s)
5	Ready state Status/Diagnostic indicator shows steady green
6	Learn is complete -

Teach the Unique Actuator

(one-time learn only; unit locked)

Initial Teach of the Actuator

The sensor automatically starts the learn process once an actuator enters the sensing range.

Table 5 - Learn Sequence

Step	Description
1	Target present Status/Diagnostic indicator flashes green 2 Hz rate (15 s)
2	Verifying actuator Status/Diagnostic indicator flashes green/red 1 Hz rate (15 s)
3	Program sensor Status/Diagnostic indicator flashes green/red 2 Hz rate (15 s)
4	Program locking Status/Diagnostic indicator flashes green 2 Hz rate (number of learns remaining) (15 s)
5	Remove the actuator from the sensing field Status/Diagnostic indicator changes to steady red
6	Replace the actuator back into the sensing field Status/Diagnostic indicator flashes green 2 Hz rate (number of learns that remain), this action triggers the lock function.
7	Ready state Status/Diagnostic indicator shows steady green
8	Learn is complete Sensor is locked and cannot learn another actuator.

Learn a New Unique Coded Actuator

- To learn a replacement actuator, bring the actuator to be taught into the sensing range of the safety switch.
- The learn sequence is the same as the sequence for [Teach the Actuator](#).
- A sensor cannot relearn a previously learned actuator or a standard SensaGuard™ actuator.
- The sensor only recognizes the most recently learned actuator.

Unique Coded Diagnostic

Error codes for learn process. Cycle power to clear the fault.

Table 6 - Signal from Status/Diagnostic Indicator

Flashes (2 Hz)	Error Code
Green	OSSD inputs not valid.
Red-red-red-green	Cannot learn a standard SensaGuard actuator.
Red-red-red-green-green	Actuator already learned.
Red-red-red-green-green-green	Bad RFID. Target moved out of range.
Red-red-red-green-green-green-green	Exceeded learning eight actuators.
Red-red-red-green-green-green-green-green	Unit locked. Cannot learn another actuator.

OSSD Test Pulses

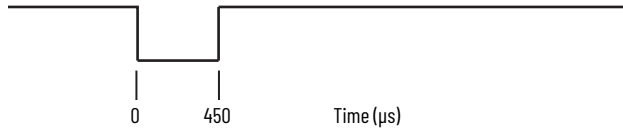

Individual Pulses

Test pulses appear on each OSSD output. These pulses are approximately every 45 ms. The times that are shown are approximate and depend on the processing of the safety-related status.

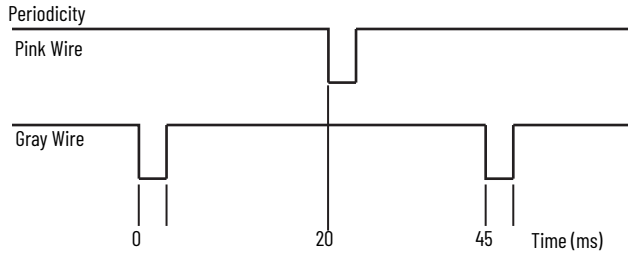

Timing Diagram

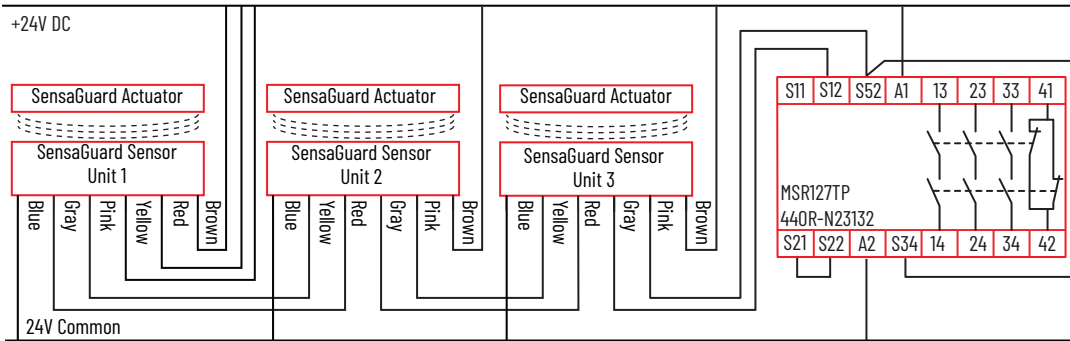

Response Time: Safety outputs turn off.

Initial conditions: All actuators are in sensing distance.

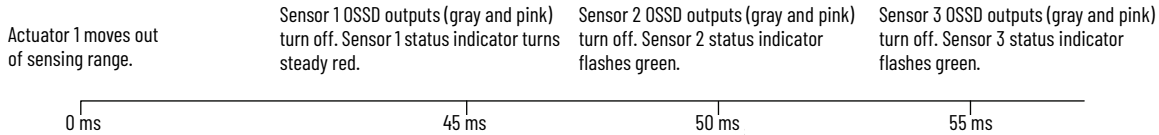

Response Time: Safety outputs turn on

Initial conditions: Actuator 1 is out of sensing range. Sensor 1 status indicator is steady red. Actuators 2 and 3 are in sensing range. Sensor 2 and 3 status indicators flash green.

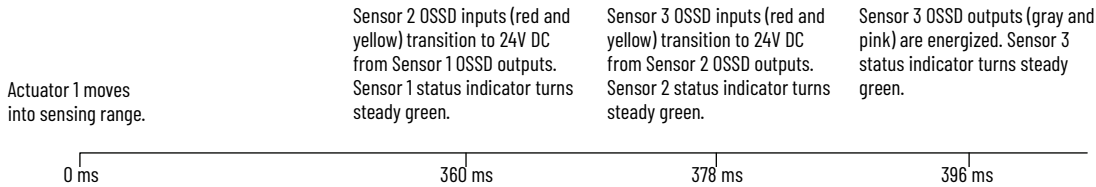

Troubleshooting

Figure 6 - Series Circuit

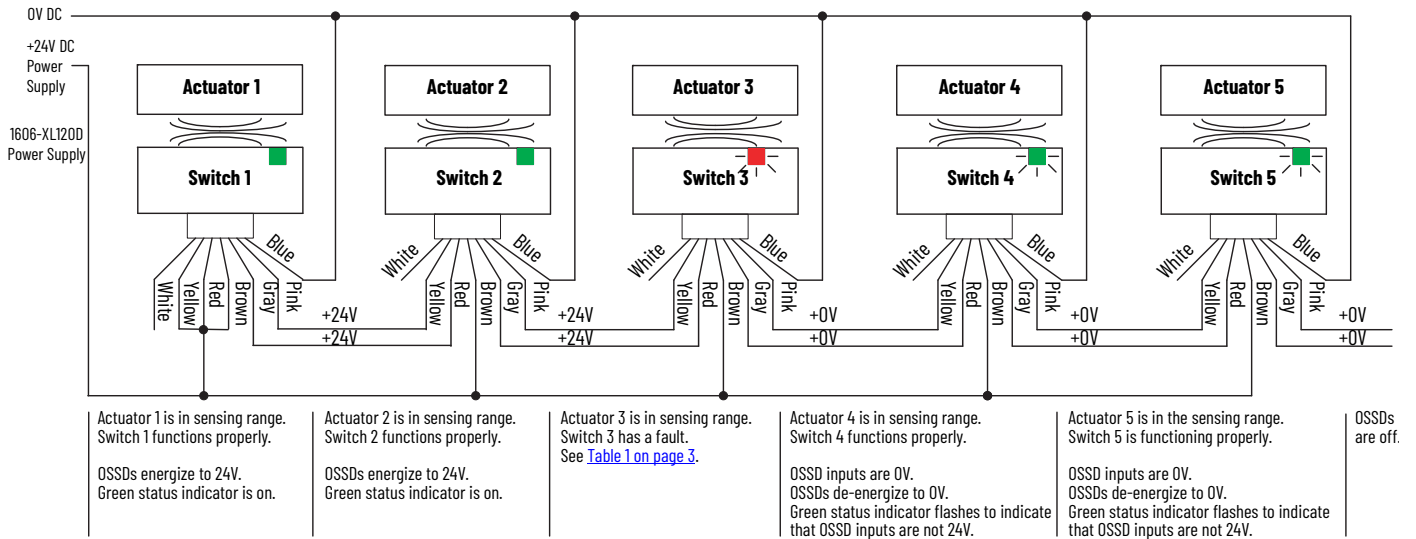

Application Wiring Examples

Figure 7 - Wiring to MSR127 Safety Relay Driving 100S or 700S Safety Relays

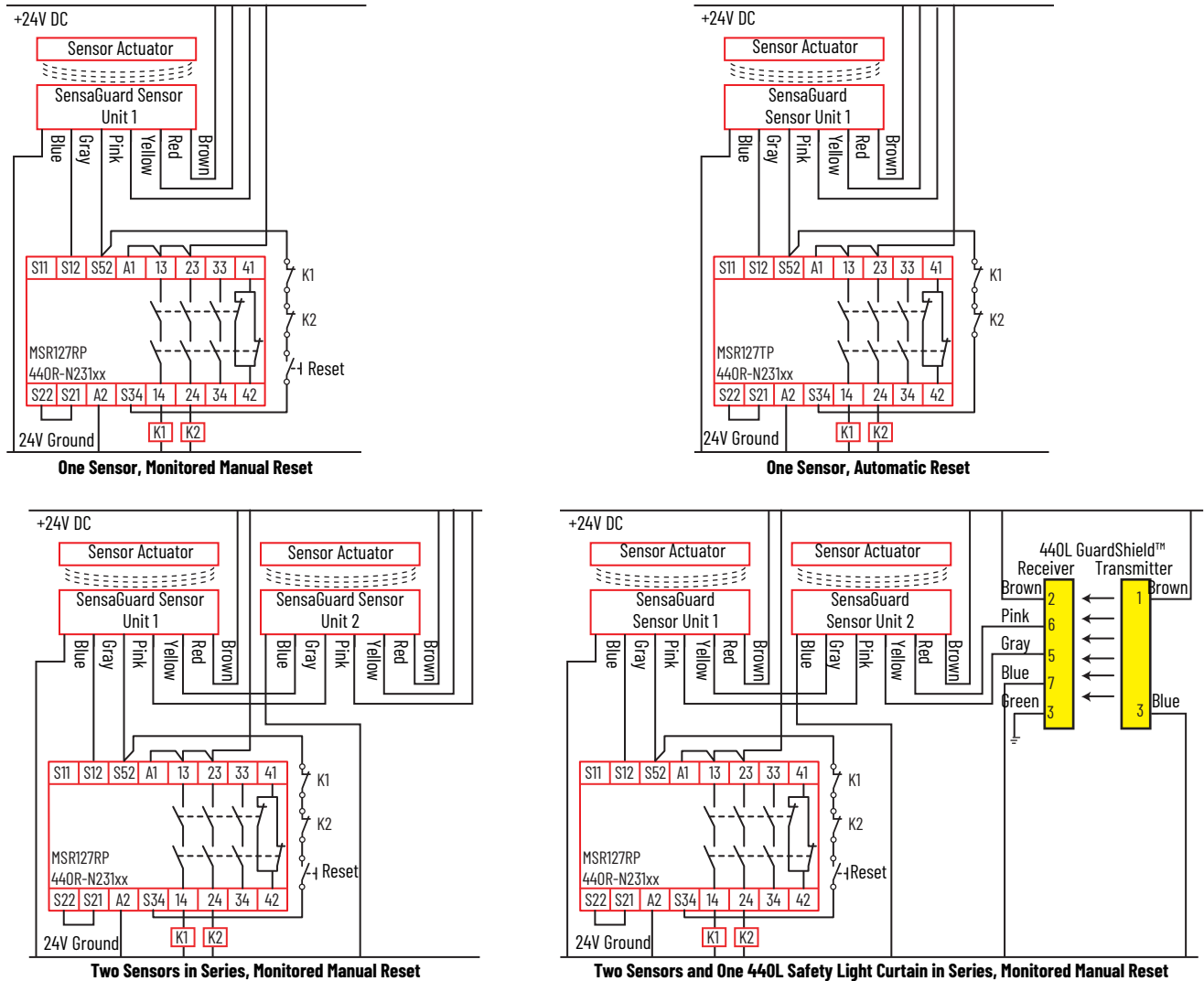

IMPORTANT The safety light curtain must be last (farthest from the safety relay).

Figure 8 - Guardmaster SI or DI Safety Relay Wiring

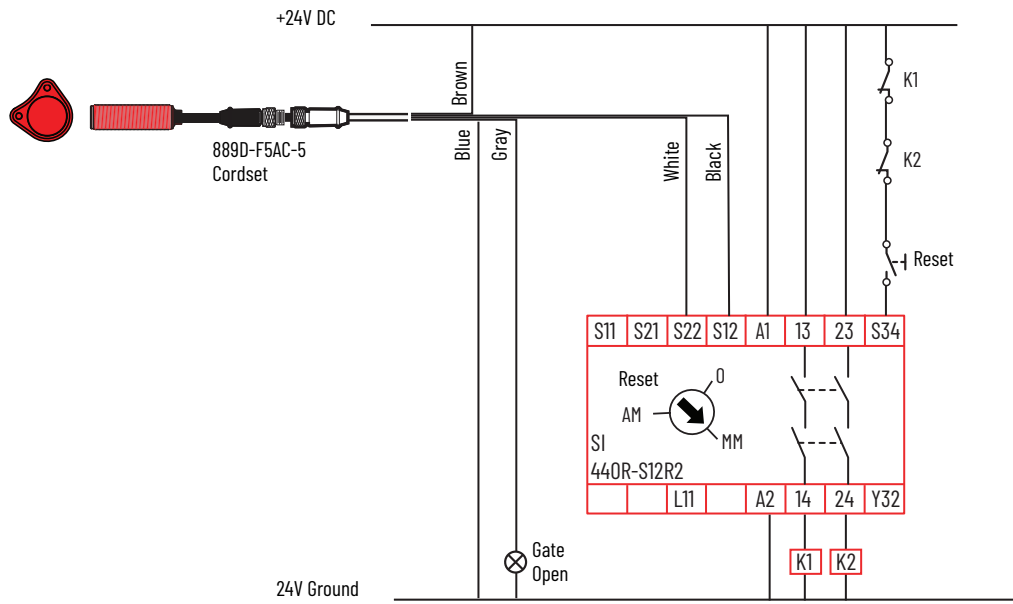
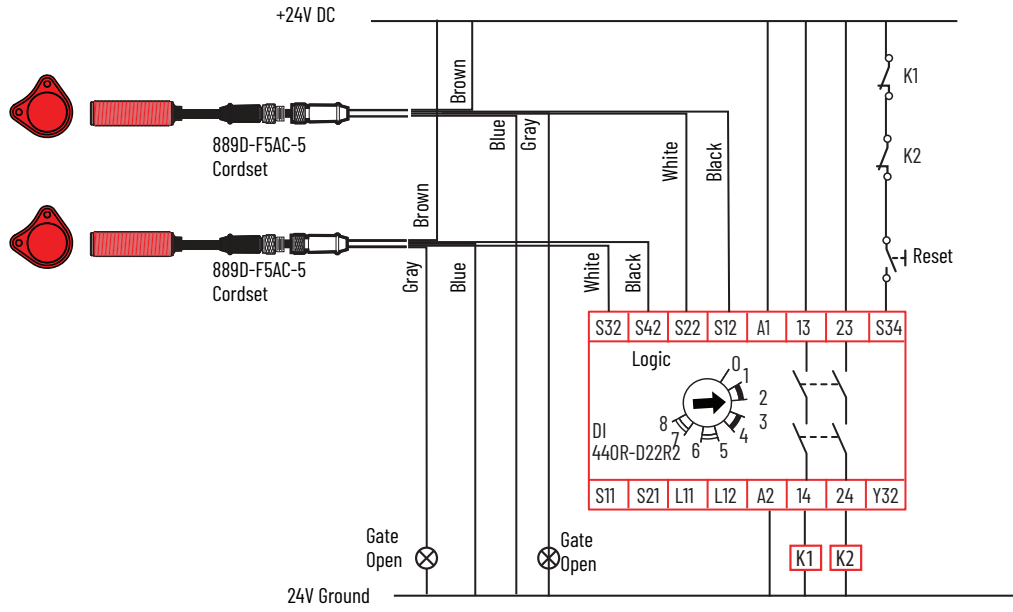
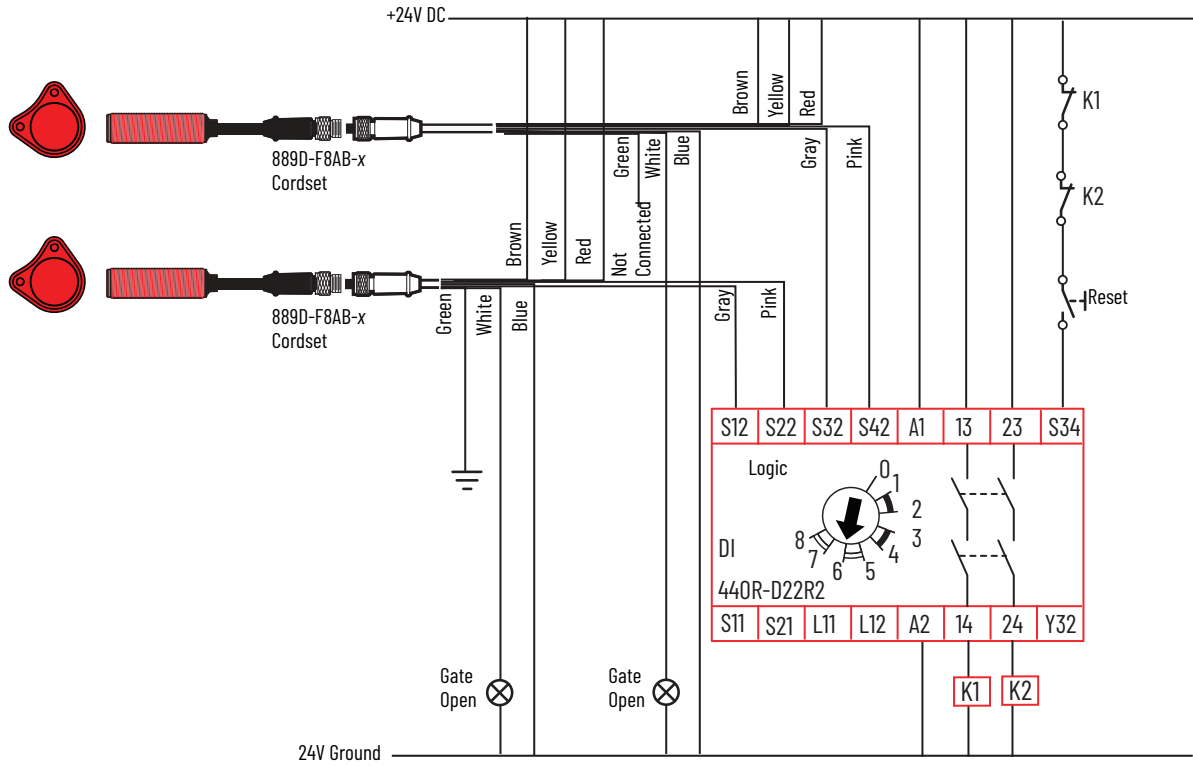

Figure 9 - Guardmaster SI or DI Safety Relay Wiring



IMPORTANT The green wire connects to the housing of the stainless-steel SensaGuard sensor only; it has no connection for the plastic SensaGuard sensor.

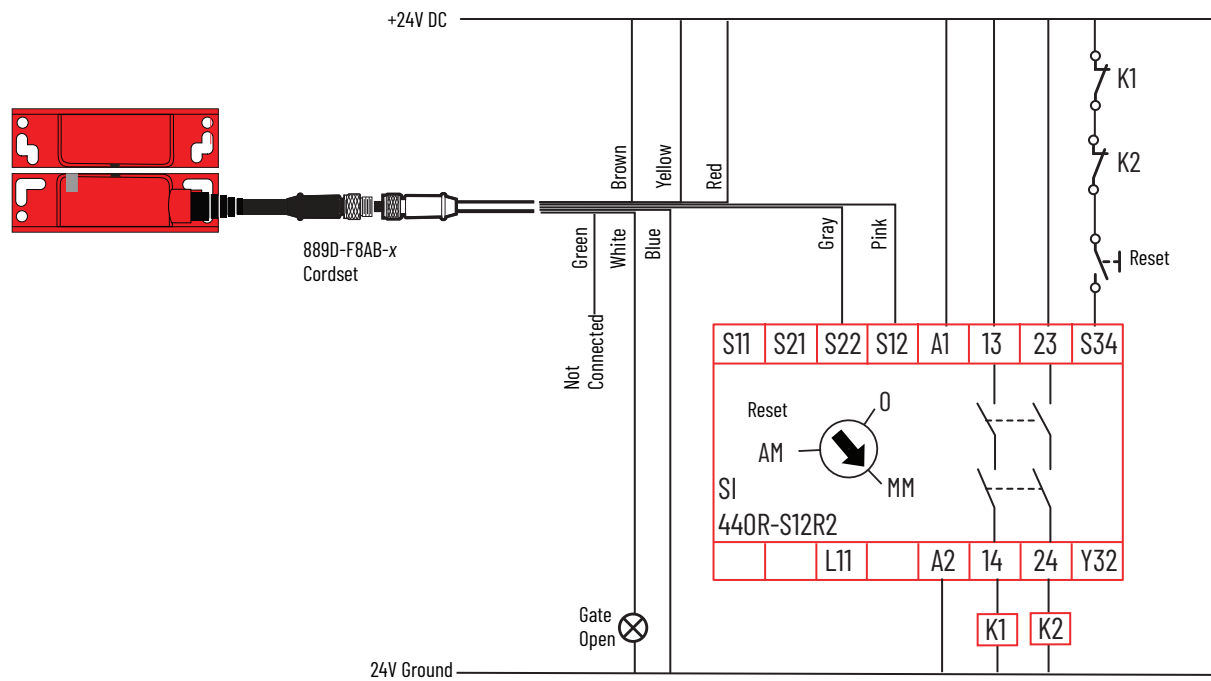

Figure 10 - CR30 Software Configurable Relay Wiring

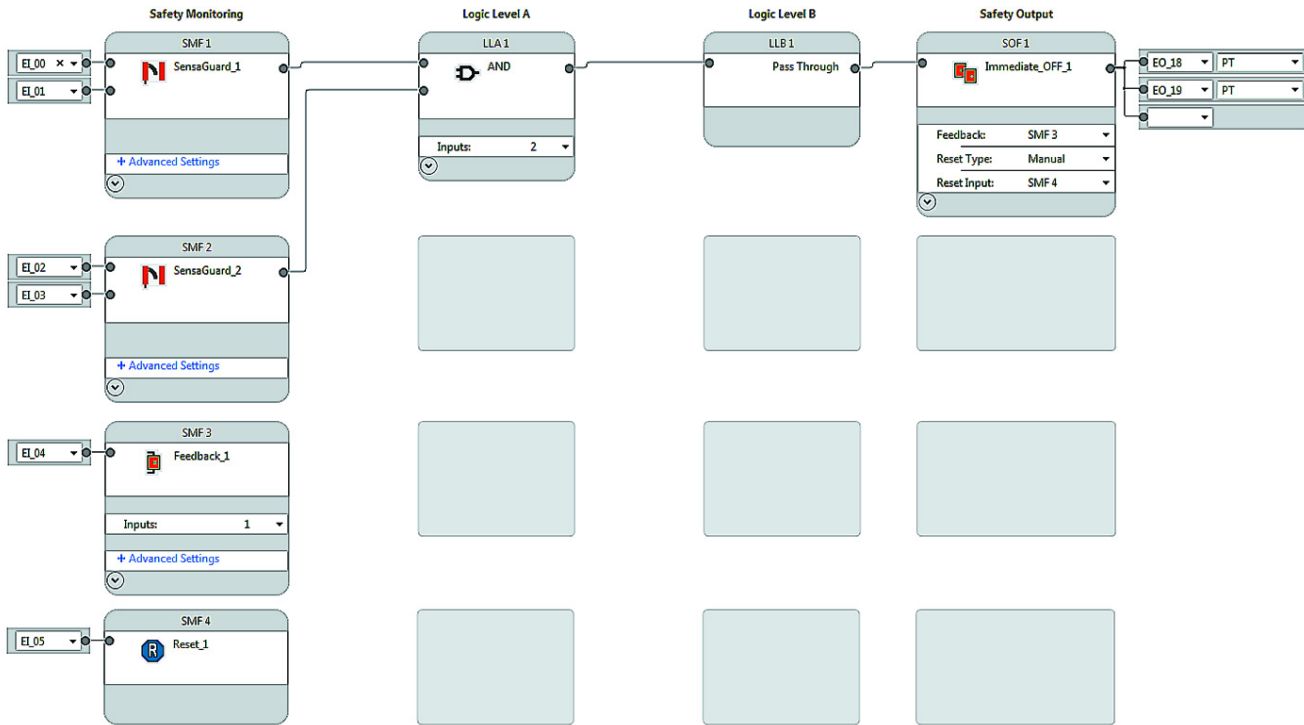
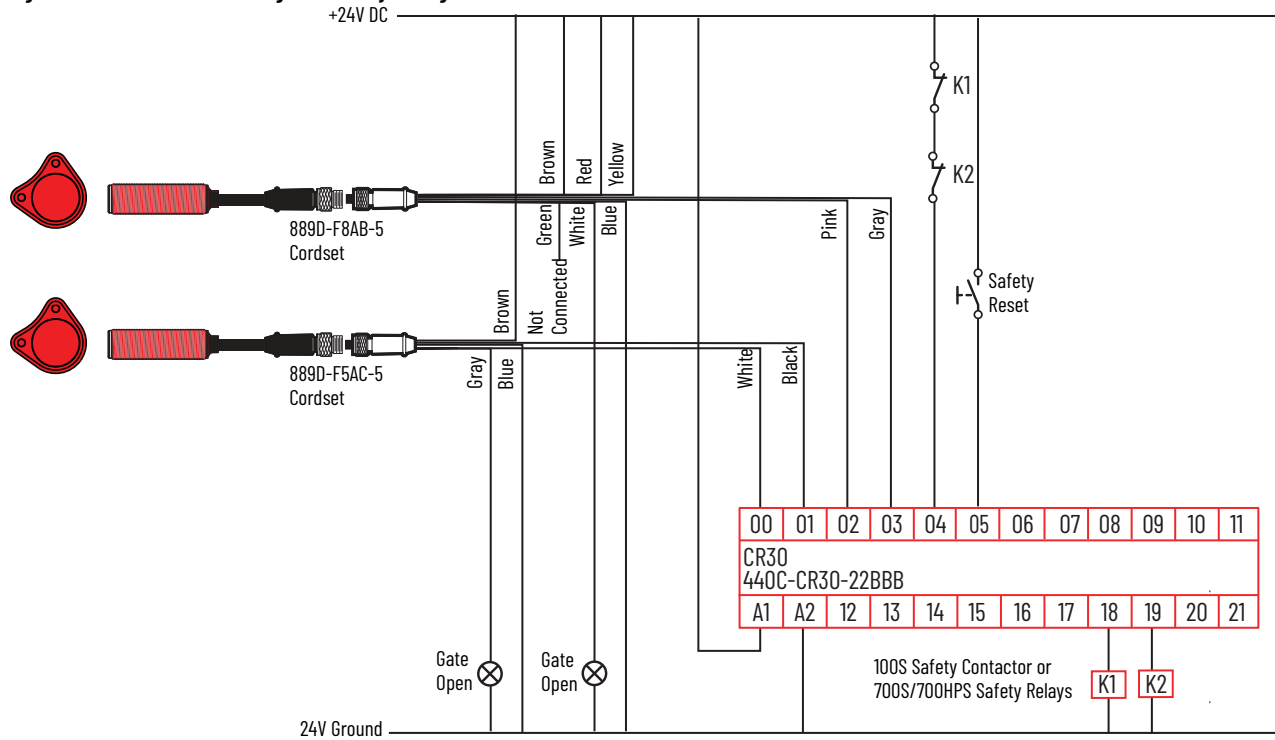
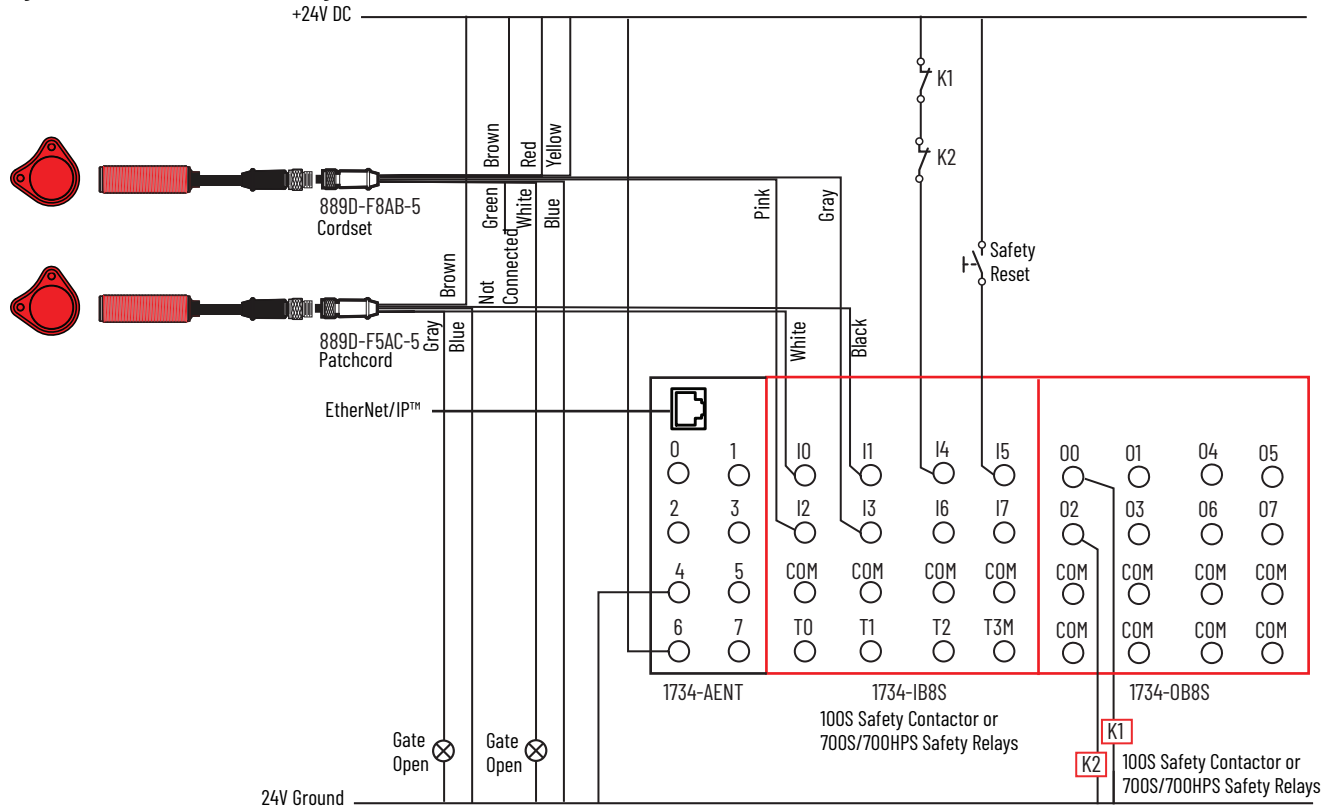

Figure 11 - 1734 POINT Guard I/O Wiring



Point	Point Operation		Point Mode	Test Source	Input Delay Time (ms)	
	Type	Discrepancy Time (ms)			Off->On	On->Off
0	Equivalent	10	Safety	None	0	6
1	Equivalent	10	Safety	None	0	6
2	Equivalent	10	Safety	None	0	6
3	Equivalent	10	Safety	None	0	6
4	Single	0	Standard	None	0	0
5	Single	0	Standard	None	0	0
6	Single	0	Not Used	None	0	0
7	Single	0	Not Used	None	0	0

Set On -> Off Input Delay Time to 6 ms to ignore the SensaGuard OSSD output test pulses.

Figure 12 - 1732DS/ES ArmorBlock Guard Safety I/O Wiring

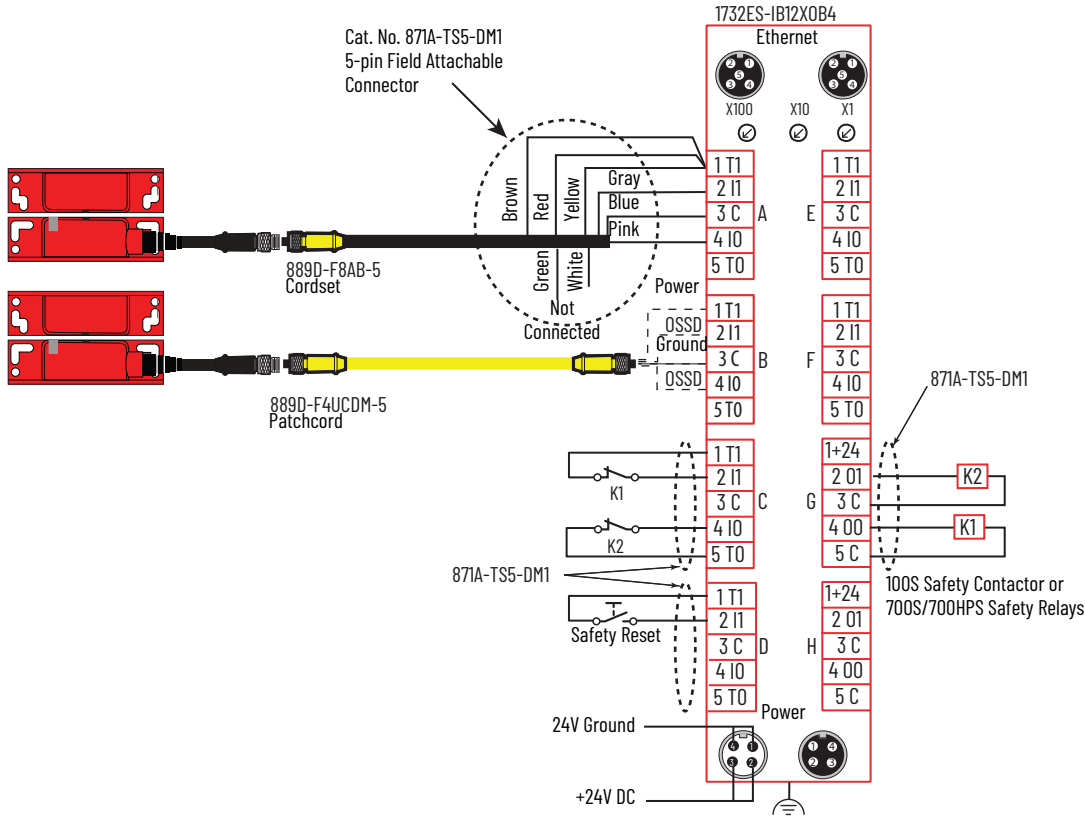
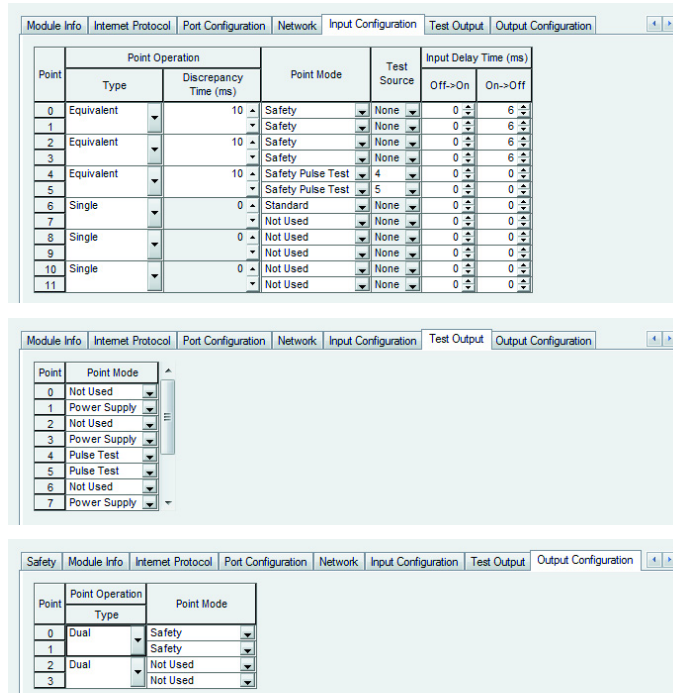

Figure 13 - Input and Output Configuration for the 1732ES Module



Recommended Safety Control Interfaces

- Guardmaster® safety relays:
 - Dual-input (DI)
 - Dual-input solid-state output (DIS)
 - Single input (SI)
 - CR30 software configurable
- Minotaur™ safety relays:
 - MSR126
 - MSR127
 - MSR131
 - MSR138
- SmartGuard™ controller
- 1791DS/ES CompactBlock™ Guard I/O™ module
- 1732DS/ES ArmorBlock Guard I/O module
- 1734 POINT Guard I/O™ module

Maintenance

Monthly: Check the correct operation of the switching circuit. Also check for signs of abuse or alterations. Inspect the switch casing for damage.

Repair

If there is any malfunction or damage, do not repair. Replace the unit before you allow machine operation.

Declaration of Conformity

CE Conformity

Rockwell Automation declares that the products that are shown in this document conform with the 2014/30/EU Electromagnetic Compatibility Directive (EMC) and 2006/42/EC Machinery Directive (MD) and that the respective standards and/or technical specifications have been applied.

For a comprehensive CE certificate visit: rok.auto/certifications

UKCA Conformity

Rockwell Automation declares that the products that are shown in this document are in compliance with 2016 No. 1091 Electromagnetic Compatibility Regulations and 2008 No. 1597 Supply of Machinery (Safety) Regulations and that the respective standards and/or technical specifications have been applied.

For a comprehensive UKCA certificate visit: rok.auto/certifications

Additional Resources

To download publications, visit rok.auto/literature and search for the following publication numbers.

Resource	Description
Industrial Automation Wiring and Grounding Guidelines, publication 1770-4.1	Provides general guidelines for installing a Rockwell Automation® industrial system.
Product Certifications website, rok.auto/certifications	Provides declarations of conformity, certificates, and other certification details.

Waste Electrical and Electronic Equipment (WEEE)







At the end of life, this equipment should be collected separately from any unsorted municipal waste.

Rockwell Automation maintains current product environmental compliance information on its website at rok.auto/pec.

Your comments help us serve your documentation needs better. If you have any suggestions on how to improve our content, complete the form at rok.auto/docfeedback.

For technical support, visit rok.auto/support.

Rockwell Otomasyon Ticaret A.Ş. Kar Plaza İş Merkezi E Blok Kat:6 34752, İçerenköy, İstanbul, Tel: +90 (216) 5698400 EEE Yönetmeliğine Uygundur

Connect with us.    

rockwellautomation.com — expanding **human possibility**®

AMERICAS: Rockwell Automation, 1201 South Second Street, Milwaukee, WI 53204-2496 USA, Tel: (1) 414.382.2000, Fax: (1) 414.382.4444

EUROPE/MIDDLE EAST/AFRICA: Rockwell Automation NV, Pegasus Park, De Kleetlaan 12a, 1831 Diegem, Belgium, Tel: (32) 2 663 0600, Fax: (32) 2 663 0640

ASIA PACIFIC: Rockwell Automation, Level 14, Core F, Cyberport 3, 100 Cyberport Road, Hong Kong, Tel: (852) 2887 4788, Fax: (852) 2508 1846

UNITED KINGDOM: Rockwell Automation Ltd. Pitfield, Kiln Farm Milton Keynes, MK11 3DR, United Kingdom, Tel: (44)(1908) 838-800, Fax: (44)(1908) 261-917

Allen-Bradley, ArmorBlock, CompactBlock, expanding human possibility, Guard I/O, Guardmaster, GuardShield, Minotaur, POINT Guard I/O, Rockwell Automation, SensaGuard, and SmartGuard are trademarks of Rockwell Automation, Inc.

EtherNet/IP is a trademark of ODVA, Inc.

Trademarks not belonging to Rockwell Automation are property of their respective companies.

Publication 440N-IN017C-EN-P - May 2023 | Supersedes Publication 440N-IN017B-EN-P - April 2019

Copyright © 2023 Rockwell Automation, Inc. All rights reserved. Printed in the U.S.A.